



TRIAD-ORBIT[®]

ADVANCED STAND SYSTEMS



REVOLUTIONARY



The proprietary base design of Triad Articulating Tripod Stands provides the weight and stability of large diameter cast iron stand bases and a fully adjustable attitude and footprint, thanks to the patent-pending ratcheting mechanism of the articulating legs. IO Quick-Change Couplers are standard equipment on all Triad Stands. IO couplers capture booms, mics and lights with ease and assurance,*On-the-fly' hardware swaps are now a reality, replacing the tedious task of threading booms, mic clips and miscellaneous mounts on and off, The IO-H Coupler Head features the industry-standard 5/8-inch mounting thread.

Triad Stands utilize industrial-grade clutches in lieu of knobs and thumbscrews to adjust and secure shafts and bases. With no protruding parts, Triad Stands transport and store with total reliability. Metal clutch barrels are coated to provide a comfortable ergonomic grip that yields more torque. TRIAD T3 and T2 Tripod Stands feature Air Suspension Systems to protect expensive studio microphones and lights against accidental impact damage.

Triad Stands have a unique patented "No-Drop" tube system.



IO Quick-Change Coupler



Comfort-coated ergonomic metal clutch barrels



Model	Collapsed Length	Max Height	Total Weight
TM	17.7" / 45 cm	23.2" / 59 cm	7.9 lbs / 3.6 kg
T1	21.6" / 53.5 cm\	35.8" / 91 cm	9.5 lb / 4.28 kg
T2	35" / 89 cm	67.3" / 171 cm	11.9 lb / 5.4 kg
T3	32.3" / 82 cm	78.5" / 200 cm	13.3 lb / 6.3 kg

Except for TM, all Triad Stands have a mounting holes for our TC casters.





Each leg of a Triad Stand base has four ratcheted positions that provide a pitch of up to 65 degrees to accommodate 'boom-less' front lines, uneven surfaces and stacking. A foot-actuated latch on each leg provides hands-free adjustability.

The cutaway base allows Triad Stands to be closely grouped in positions not possible with conventional stands.

Adjusting the height of the articulating legs affects the floor clearance and footprint of Triad Stands.

The height specifications of Triad Stands are measured when the articulated legs are in position 1. The height of Triad Stands increase when the articulating legs are in positions 2-4.

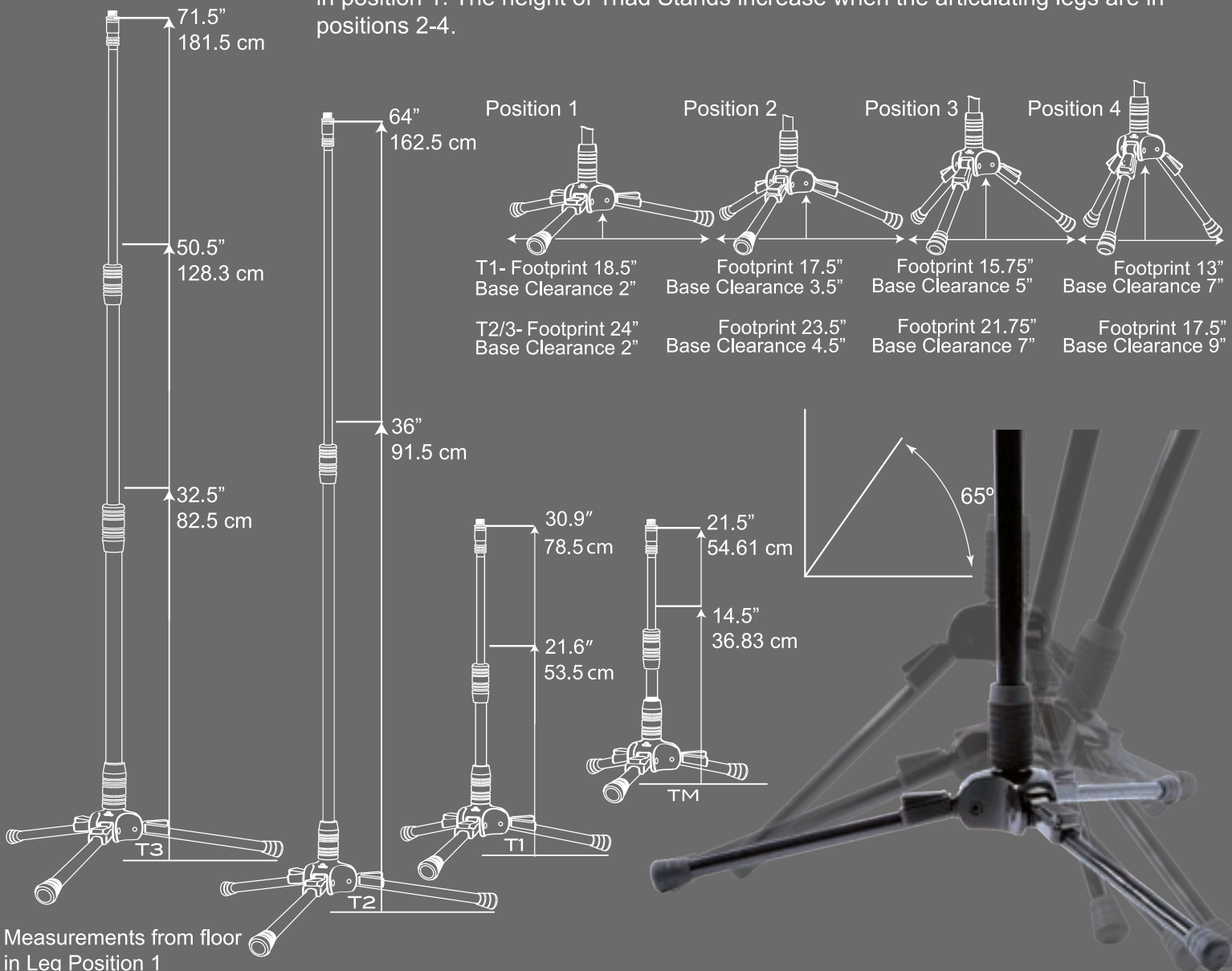

Measurements from floor in Leg Position 1

ORBIT BOOMS®



ORBIT orbital booms utilize a stainless steel ball swivel mechanism to deliver an unparalleled range of motion that's extremely smooth, quiet and stable.

The Orbit swivel housing exhibits a full 360° degrees of horizontal rotation. Add to that the 360°x 190° rotational axis of the ball swivel mechanism, and you have the most precise and versatile booms ever made.

The ORBIT orbital boom is – in a word - revolutionary. With its proprietary ball swivel and robust build quality, surgically precise device placement is now attainable in every recording, live, film, lighting or livestream scenario.



ORBIT Booms utilize industrial-grade clutches in lieu of knobs and thumbscrews to secure all points of adjustment on the shafts. The knurled metal clutch barrels are coated to provide a comfortable ergonomic grip that yields more torque.

Model	Collapsed Length	Max Length	Total Weight
O1-L	26.5" / 67.31 cm	37.5" / 95 cm	4.75 lb / 2.15 kg
OM	12.2" / 31 cm	21.65" / 55 cm	4.25 lbs / 1.93 kg

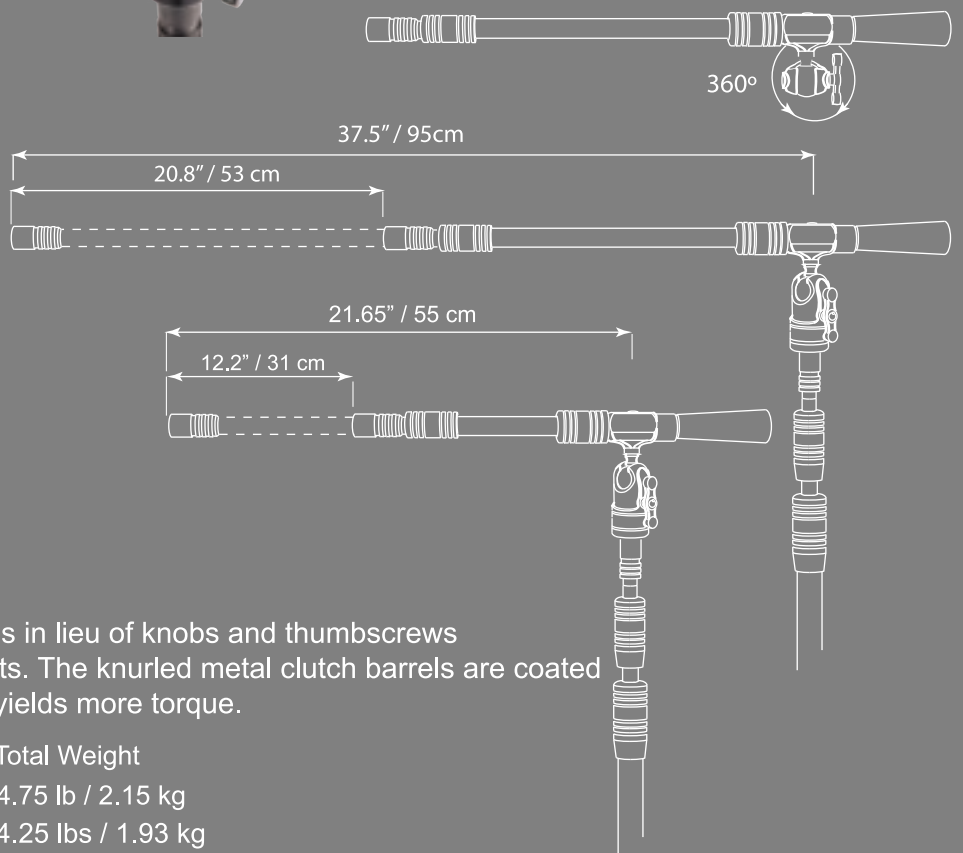
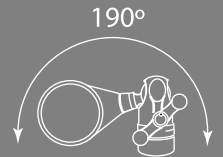

ORBIT 2

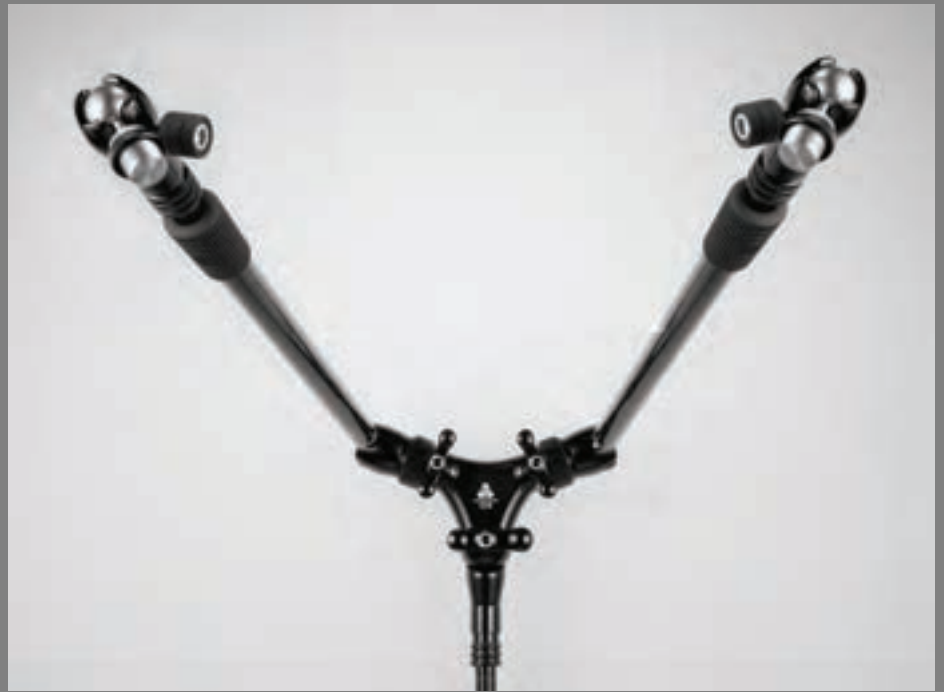

ORBIT 2 Dual Orbital Booms feature a unique dual-arm design. Each arm is equipped with the proprietary Orbit ball swivel mechanism, making it the 'go-to' stand for stereo or dual miking assignments such as grand pianos, drum kit overheads, snare drum (top & bottom), guitar and vocals, choirs, big bands, and orchestras. ORBIT 2 Booms do the work of two stands, freeing up resources when multiple mics are called for and space is limited.

Combining Orbit Booms with Micro Mic Adapters creates an advanced microphone placement system with unequalled accuracy and adjustability.

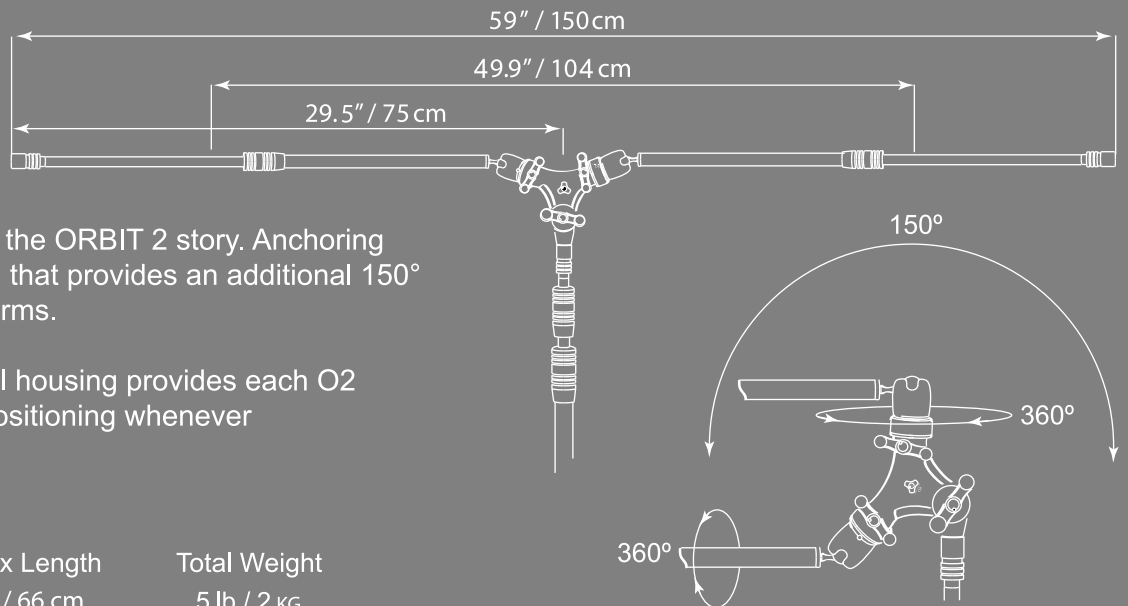

Dual boom arms are only part of the ORBIT 2 story. Anchoring ORBIT 2 is a novel center swivel that provides an additional 150° of left-right motion to the boom arms.

The Compass Point™ ball swivel housing provides each O2 boom arm with precise, stable positioning whenever the arms are engaged.

Model	Collapsed Size	Max Length	Total Weight
O2	17.7" / 45 cm	26" / 66 cm	5 lb / 2 kg

ORBIT 2X™ / O2X™ AND O2XY™

Dual Orbital Boom System featuring 4 IO-A Quick-Change Boom Arms

Orbit 2x dual orbital boom system extends the utility of the original O2 dual boom with the addition of detachable arms via IO Quick-Change Couplers. Four IO-A telescopic boom arms are included, (2, IO-A1A short arms and 2, IO-A2A long arms) in the system, allowing users to custom-configure a dual boom to adapt to a multitude of tasks in seconds.

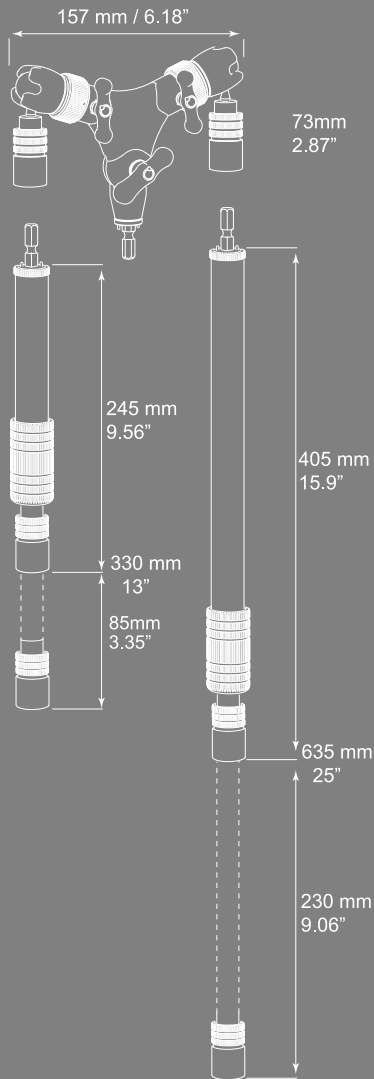

O2x shown on a T1 with IO-Vector and 3, M2 adaptors.



O2x shown on a T3 with 2, M2 adaptors.



Range of Motion: 360° x 230°
Center Swivel Range of Motion: 150°

Orbit 2x orbital booms utilize stainless steel ball swivel mechanisms to deliver an unparalleled range of motion that's extremely smooth, quiet and stable. Adding Micro 2/ M2 adaptors ties the system together for unlimited mic, camera or light positioning.



O2XY™

O2XY is a stand alone O2x boom main body with two connections via IO Quick-Change Couplers. Perfect for if you already own an O2x or have extra IO-A1A or IO-A2A arms.

IO-A1A Aluminum Arm



IO-A2A Aluminum Arm



IO-A1A Aluminum Boom Arm Range: 9.5-12.5-in. • IO-A2A Aluminum Boom Arm Range: 15.5-24.75-in.
Use in conjunction with an IO-Vector to create a mobile Decca Tree.



ORBIT ARM / OA IO Quick-Change Ball Swivel.

The Orbit OA is a freestanding version of a single Orbit 2-type orbital boom arm. Attach OA to IO-C and IO-GC and IO-GCM clamps, IO-VM or IO-W / IO-WSP wall plates for instant connectivity to walls, ceilings, consoles, etc. Add an optional IO-A1A or IO-A2A for added length and adjustability.

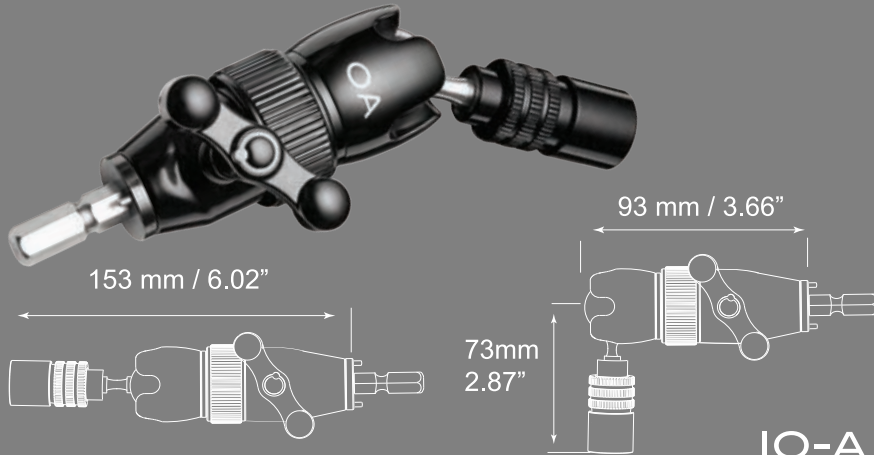

IO-A TELESCOPIC BOOM ARMS

IO-A telescopic boom arms allow users to custom-configure a number of T-O products to adapt to a multitude of tasks in seconds.



IO-A1A, Range: 9.6" to 13"



IO-A2A, Range: 15.9" to 25"



Use in conjunction with an IO-Vector to create a mobile Decca Tree.

IO FLEX

The IO Flex IO-Equipped Flex Extension is a unique, flexible extension with our quick-change head and receiver to adapt and position any IO-Equipped accessory where you want it.



RIGID EXTENSIONS

IO-EXT-8 and EXT4 are 8" and 4" rigid extensions for applications that require extra reach to provide the user more flexibility to place the audio/video/lighting device in the desired location.



IO-EXT2S has a 360° rotational IO connector that can be added to existing stationary IO-connections such as the IO-W or IO-GC / IO-GCM

T-ES ELEVATOR SHAFT™

T-ES is a 33" extension for TRIAD stands. Equipped with IO Quick-Change Couplers, the T-ES is designed to elevate microphones for choral and orchestral applications, ambient recording, wireless transmitter antennas, etc.



OA-M



OA-M Orbit Arm Mini has the diversity of the larger OA, but in the footprint of our micro adapters. Great with microphones when using the included IO-H2 adapter, and can also be used with our short extensions as a small boom arm that attaches to stands, consoles, desktops, walls when paired with an IO-C clamp or IO-W wall mount. For extensions larger than the EXT-8, we recommend the OA.



MICRO SERIES ADAPTERS



The MICRO Series orbital adapters are an important final key to Triad-Orbit's flexibility. Micros feature the exclusive Compass Point™ ball swivel housing that solidly secures microphones, cameras, and lights in position for precise directionality. The short stem mounting arm is purpose-built to reduce setup time for those who need precision placement. M2 and M3 adapters are IO-equipped for quick-change compatibility with TRIAD microphone stands, ORBIT booms and IO-RA couplers. M2-R and M3-R have 5/8-27 threads to adapt to any standard stand or boom.



Starbird™

SB-1 STUDIO BOOM STAND

T.A.F. (Triad Air Force)™ is a patent pending, pneumatic system that automatically and effortlessly raises the stand and boom when you're dealing with high extensions and heavy loads.

BOOMSTOP™ is a safety spring-pin locking mechanism that secures the boom in any of 13 positions, for stable, worry-free mic positioning.

VARIBAL™ offers effortless, adjustable 10lb. counterweight positioning and the ability to add additional ballast to the counterweight as needed.

STARBASE™ is a massive cast iron base with retractable legs that pivot for optimum positioning and tuck away under the base for smaller studios and efficient space saving storage.



STARBASE
RETRACTABLE BASE





OA™ IO Quick-Change compatible
and includes the OA ball joint for 360°
of mic adjustment.

TECHNICAL SPECIFICATIONS

Stand Height Range:
1.6 m / 63 in - 2.6 m / 102 in
Boom Length Range:
1.4 m / 55 in - 2.5 m / 98 in
Base Footprint Range:
46 cm / 18 in - 98 cm / 38 in
Stand Weight: 30 kg / 66 lb



IO-RA™

Retrofit Quick-Change Coupler



IO-RA (Retrofit) couplers are designed to add IO quick-change innovation to your existing stands. With IO-RA, 'on-the-fly' hardware swaps are now a reality, replacing the tedious task of threading gear on and off.

The exclusive "Cam Lock" secures IO-RA couplers to stands without damaging mounting threads. Thread the IO-RA coupler onto any mic stand or boom equipped with 5/8 inch threads until tight. Then lock the IO-RA in place by tightening the 3mm hex screw with the included hex wrench.

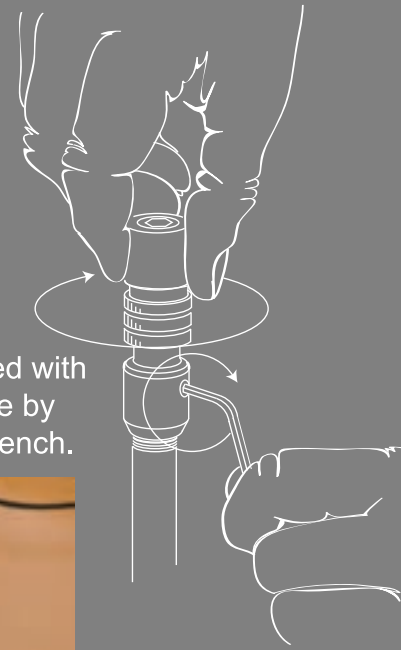

IO-RL™

Lighting Stud Retro Quick-Change Coupler

IO-RL is the first full-size quick-change coupler built specifically for photo/video lighting support. IO-RL enables instant hardware swaps, replacing the tedious threaded screw and hole connections between lights, modifiers and stands. IO-RL provides a faster, more secure, hassle-free method of connecting speed flashes, lights and modifiers to stands and booms with zero spin out.



IO-H™ Mounting Heads

The ever expanding IO-H family of hex mounting heads include: IO-H2 5/8 in. w/stainless steel hex shaft and safety stop™, IO-H3 3/8 in., IO-H4 1/4-20 in., IO-H5 5/8 in. lighting stud 1/4-20, IO-H6 baby pin, IO-G GoPro™, IO-HMM male turn around.



IO-H2

IO-H3

IO-H4

IO-H5

IO-H6

IO-G

IO-HMM

IO-C™/IO-C2 Mounting Clamps with IO Quick-Change Couplers

IO-C series mounting clamps are purpose-built for attaching Triad-Orbit IO-equipped adapters, boom arms, tablet holders and assorted accessories to stands, trusses, tabletops and other parallel surfaces. Create unique solutions and multipurpose setups easily by adding an OA, OA-M, EXT2, 4, 8 and/or Micro adapters.



IO-C

IO-C has a wide soft silicone rubber to avoid marring surfaces.

IO-C2

IO-C2 is mini clamp has firm rubber with extreme hold for its size.



IO-GC/IO-GCM Grip Clamps with IO Quick-Change Coupler



IO-GC



IO-GCM

IO-GC/IO-GCM each have unique articulating jaws that fit jaw, allowing for multiple instruments or device mounting firmly onto any odd shaped object. Whether mounting on round, square, or flat objects, the peak-and-valley design of the jaw allows for multiple points of contact, ensuring a strong grip every time. IO-GC is tapped with one 1/4"-20 and one 3/8"-16 threaded hole on each of the jaws and the IO-GCM has one 1/4"-20 threaded hole on the opposite side of the IO.

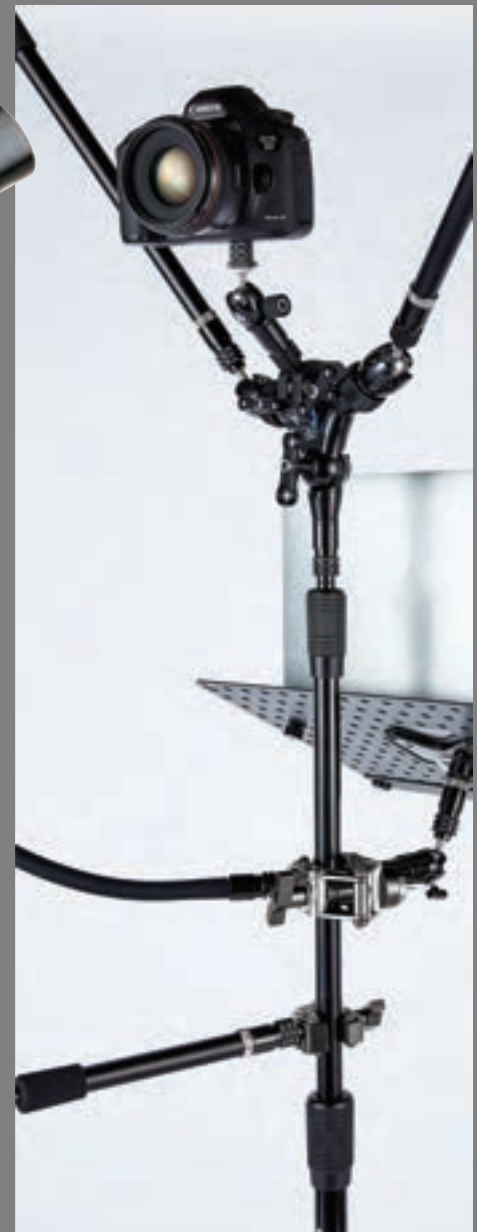

IO-VECTOR™

Stereo Utility Bar



IO-R38™ quick-change coupler is also sold separately.

Triad-Orbit's IO-Vector takes the traditional stereo bar to a new dimension, literally. IO-Vector provides five points of connectivity for 3-D positioning of microphones, cameras, lights and other creative devices. IO-Vector is equipped with two IO quick-change couplers and includes IO-R38™ quick-change coupler and 4 IO-H2 mounting heads.

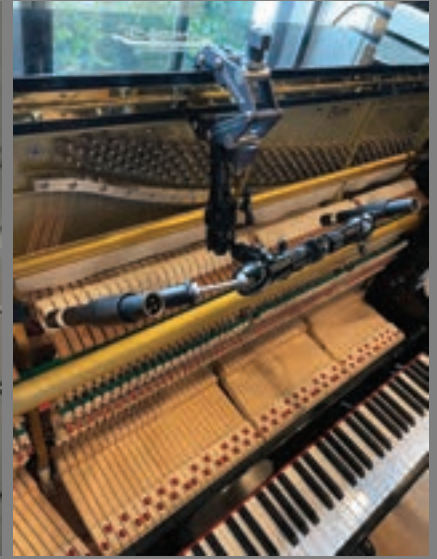

IO-LCK

IO-LCK is a rigid locking joint using a "Hirth" joint connection for ultimate hold. Our strongest and most rigid joint, use IO-LCK to support heavier loads, such as monitors, tv's or speakers. IO-LCK has a 360° rotational IO (in/out) receiver to allow for precise positioning. Combine IO-LCK with an IO-W mount or IO-WSP wall stud plate for secure wall mounting options. Perfect for wall mounted screens.

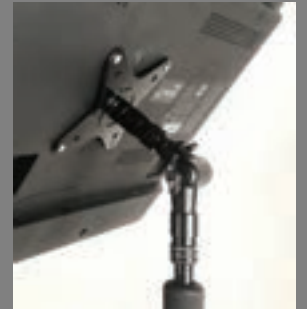

IO-RCK

IO-RCK is an IO-Equipped mount for connections to professional 19" equipment rack spaces. This cutting-edge rack solution has been designed with the needs of modern musicians and producers in mind. The IO-RCK fits seamlessly into any rack space, providing unparalleled versatility and flexibility for gear mounting and positioning.



O-VM

IO-VM is a MIS Class D VESA mount optimized for securing, supporting and positioning 12" to 32" video displays. The IO-VM mount works hand-in-hand with Triad-Orbit's innovative OA orbital arm. Pair IO-VM with Triad T3 / T3C stands, IO-C clamps or IO-W wall plates for new support solutions in any location or application. Mounting and stowing IO-VM-equipped displays is effortless, thanks to the IO quick-change coupler.



Hole Pattern: 100mm x 100mm & 75mm x 75mm

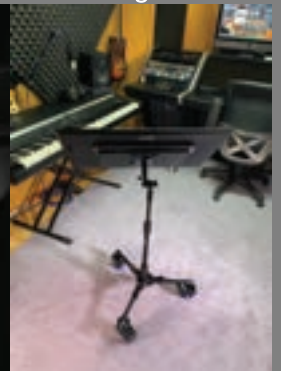
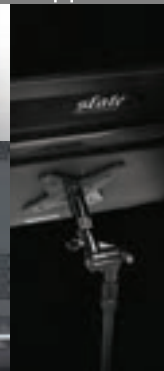
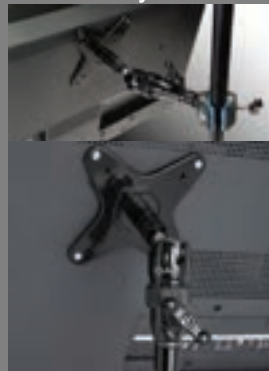

Use with OA, IO-LCK, IO-C, IO-GC clamps, IO-WSP Wall plate or T3C Stand.

IO-W™

Wall plate / Desktop Mounts with IO Quick-Change Coupler.

IO-W wall plates provide a stable platform for mounting Triad-Orbit IO-equipped adapters, boom arms, tablet holders, and assorted accessories to flat surfaces, including walls, ceilings, desktops, and consoles. IO-W features an EVA isolation pad to reduce the transmission of vibrations and protect delicate surfaces from finish damage. IO-W also makes a great freestanding portable desktop mic or tablet stand (when paired with iOrbit) that can be moved to any needed location. Gain floor space, eliminate clutter, and use fewer stands by mounting AV devices to IO-W.



IO-WSP™

Stud plate / Desktop Mounts with spinning IO Quick-Change Coupler.

IO-WSP stud plate is similar to our popular IO-W wall/desk/ceiling mount with a shape designed for stud wall installation and a 360 degree rotational IO connection to allow for precise adjustment of monitors, speakers, or other devices.

IO-S6™

AVID S6 Console Quick-Change Coupler

IO-S6 connects to the rear of Avid S6 consoles on the mounting frame and provides IO (In/Out) connectivity to add your favorite accessories, such as LCD monitors, speakers, cameras, microphones, sheet music. Pair with IO-A1A / IO-A2A or OM boom for microphones and other IO products.



IO-S6 holding monitor with OA, IO-LCK and IO-VM



IO-SPKR™

IO Quick-Change Couple Speaker Plate

IO-SPKR is IO-Quick Change Coupler head and plate that fits two hole speakers with span of 50mm-130mm. They can be used with IO-W, IO-WSP wall plates, IO-GC or IO-GCM clamps and on Triad stands. Use OA ball joint or IO-LCK as the speaker swivel. T3 stands are highly recommended due to their weight and low center of gravity.



TDS™

Triad Desk Stand
Triad Desk Stand small portable desk stand with IO connectivity. TDS has a wide footprint 260mm (10.25") with a surprisingly low center of gravity, and weighs in at 1.4 lbs. With a max height of 7.9" it is perfect for placing devices on a desk, conference tables, or console.



iORBIT

Tablet / Smartphone Holder including IO-C Quick-Change Clamp



iOrbit is a universal smartphone and tablet holder with clamping jaws that adjust from a width of 6cm to 27.5cm (2.4 in. to 10.8 in.). iOrbit features a stainless steel ball swivel enclosed in a cast alloy housing that provides a smooth 360° range of motion and four 90° crenels for unparalleled support and positioning. The iOrbit ball swivel also features a Triad-Orbit IO hex mounting head to effortlessly connect to the included IO-C clamp or any Triad-Orbit accessory.

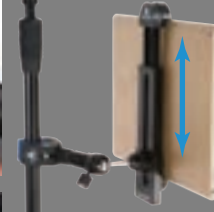

Movable Center Point

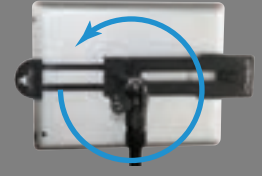

360° x 180° Rotation



Included IO-C clamp

IO-DESK

Laptop Support System

IO-Desk is a secure support platform for laptops and power supplies. IO-Desk features a sturdy 3mm aluminum plate equipped with (180) 3/8-16 threaded holes and (4) 5/8-in mounting holes with corresponding device fasteners. IO-Desk includes the perforated aluminum mounting surface, (2) 5/8-in locking fasteners, (2) 3/8-in laptop fasteners, with padded hardware, (2) 3/8-in. power supply fasteners with straps, (1) IO-H and a music stand adapter bracket.



IO-STRING SWING™

Quickly and securely hang your favorite instruments off of Triad-Orbit stands or wall mounts with the new IO-equipped yokes brought to you by Triad Orbit and String Swing. Each IO-String Swing yoke comes with a threaded hex adaptor for use with all IO-equipped connections. Yokes can also be used without a hex adaptor by threading the yoke into a 1/4-20 hole found on our IO-GC and IO-GCM grip clamps.

*An IO-R38 can be threaded on the opposite jaw of an IO-GC clamp to accommodate a 2nd IO-connection to allow for an additional instrument or device, such as an iPad via our iOrbit tablet holder.



CABLE CONTROL

Cable Control is a support stand cable management product that is rugged yet pliable and doesn't require any additional fasteners (velcro, tape, etc.). Cable Control is made of semi-rigid 10mm PET braid and is lightweight, quiet, and flexible. The overlapping edge of Cable Control tubes ensure easy installation, secure retention and fluid movement of cables in the wrap.



AV PACK

Combines 7 important Triad-Orbit IO-H™ accessories into one package. Has all the essentials to connect microphones, GoPro, DSLR cameras, video cameras, LED lights, flashes and full sized photography grip gear to your Triad-Orbit stands, Orbit booms or IO equipped devices. Plus, all of these items fit into the included accessory storage pouch.

MICRO LEVEL

Fits on an M2 or M3 allowing for precise leveling of 360 cameras, DSLR, GoPro or any video camera. Can be installed on Micro adapters between the locking ring and the IO-H4 or 1/4ADA adaptors.



T-O GO™ CARRIER BAGS

The world's finest stands deserve to travel in style. Triad-Orbit carrier bags are specifically designed to securely store and transport Triad-Orbit Stand Systems.



TSB TRIAD SHUTTLE BAG

The Triad Shuttle bag is a robust rolling transporter with a two-tier compartment designed to provide separation for multiple stands & booms, Micro Adapters, and accessories. Individual Velcro pads provide separation, stabilization and protection for your systems. The heavy-duty wheels and 2 carry handles make transport, loading, and unloading as easy as can be.



TGB-2 CARRIER BAG

Our TGB-2 Carrier Bag is made from a durable 600-Denier PVC exterior and has separate padded interior zippered sections to secure your Triad-Orbit systems during transport. The inner lid and front exterior pockets keep your accessories and various components organized and out of the way.



GB-3 GRAV BAGS

Triad-Orbit GB-3 Grav Bags are uniquely-weighted, metal-shot filled ballast bags that can be used individually on leg ends or combined as a center weight to stabilize stands in heavily-trafficked areas



BUILDING SYSTEMS

Configuration and Component Suggestions

Whether you're working in the confines of a studio or the chaos of a live stage, Triad-Orbit's modular stand system makes your job easy. If your work requires you to be as efficient as possible, then you'll love Triad-Orbit technology. Each individual component, from Orbital Mic Adapters to multi-position tripods, is noteworthy on its own, but together, they also add up to create a fully modular stand system. Swap mics, position stands, and find the sweet spot with precision accuracy, all in a matter of seconds. Whether it's Triad-Orbit's unique ball mounts or multi-position tripod bases, you'll find countless ways to improve your workflow with Triad-Orbit.

3 Piece Kit, 3 Stands

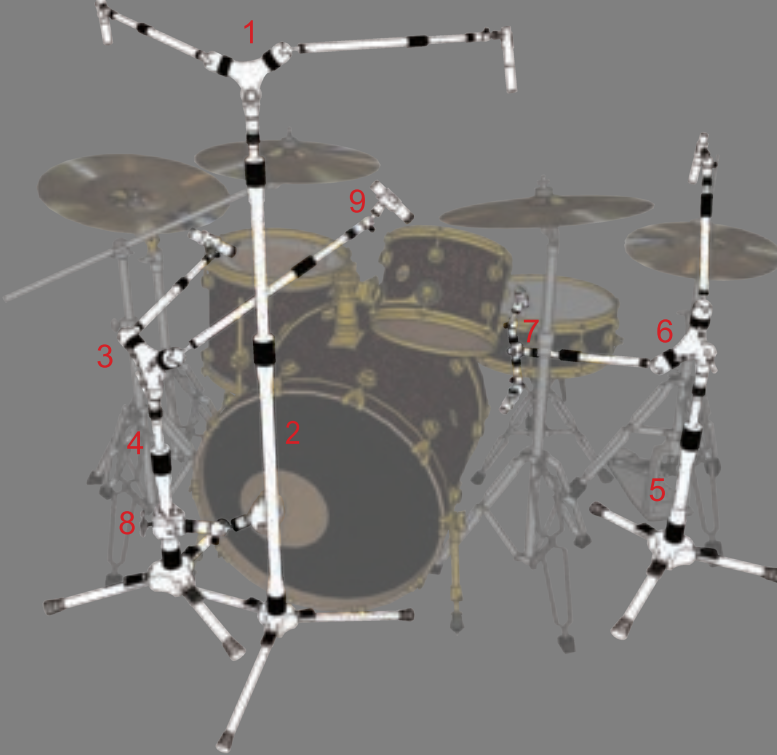

Components used on these systems: (1,3&6) O2 or O2X Dual booms. (2) T3 Stand. (4,5) T1 stands. (7) IO-Vector. (8) IO-C or IO-GCM. (9) All mic positions use M2 adapters.

Inside Piano Stereo Miking System

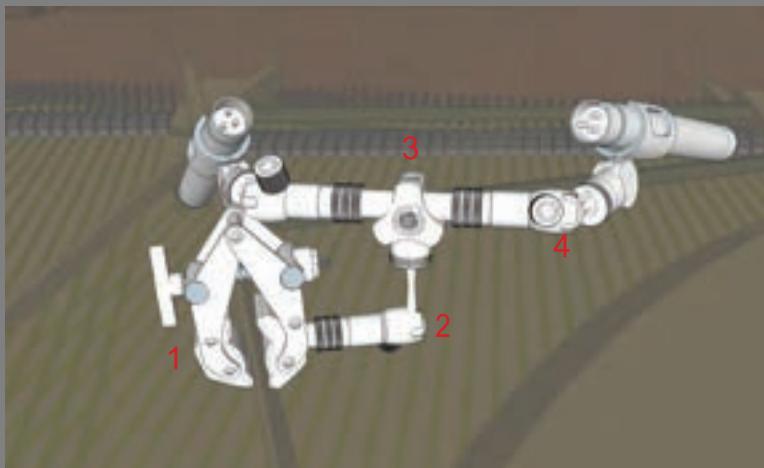

Components used on this system: (1) IO-GC. (2) M3. (3) IO-Vector. (4) 2 ea M2.

Triad-Orbit Systems are completely modular and these systems are only suggestions. There are always several options that can fit your needs or placement space. Please see our website, "Building Systems and Assemblies" for many more.

BUILDING SYSTEMS

Setups and Component Suggestions

Rolling Portable Decca Tree System

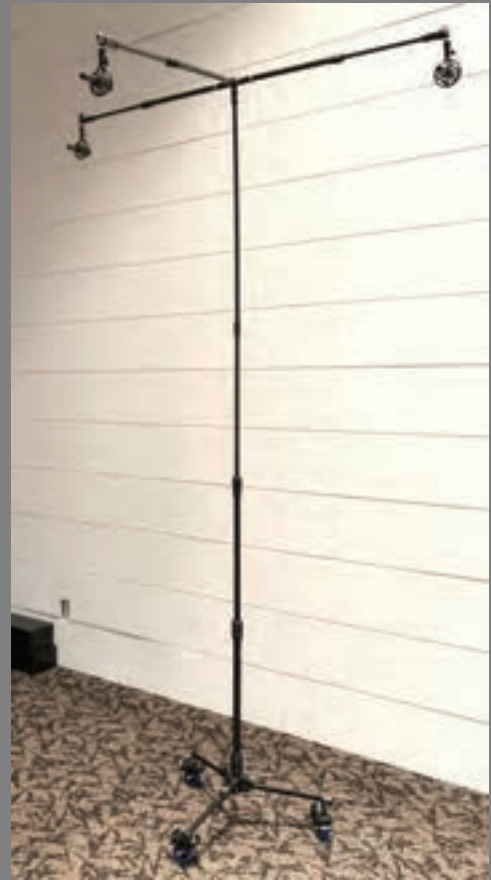
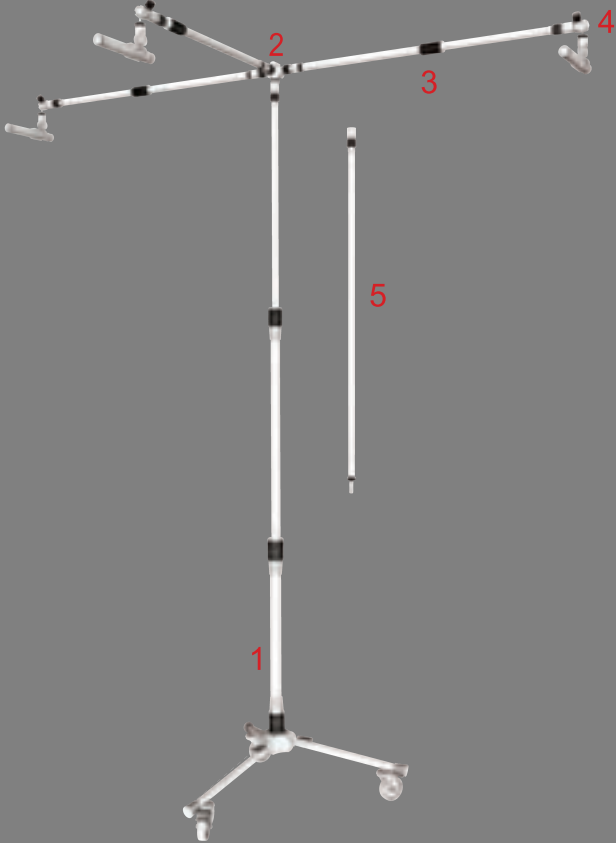

Components used in this system: (1) T3c (2) IO-Vector (3) IO-A2A arms x3 (4) M2 or M3 x3 (5) T-ES 33" extension

Short Rolling Monitor LCD Stand System

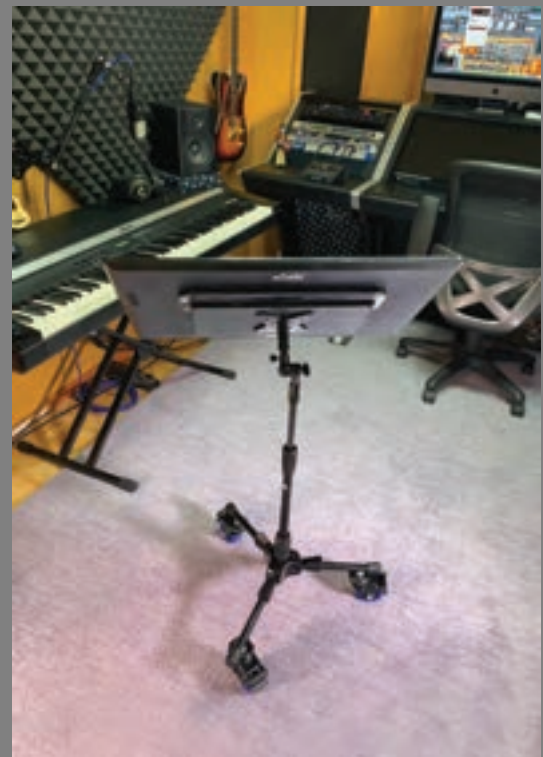

Components used in this system: (1) T1c (2) IO-LCK (3) IO-VM

Triad-Orbit Systems are completely modular and these systems are only suggestions. There are always several options that can fit your needs or placement space. Please see "Building Systems and Assemblies" on our website for many more creative ideas.

BUILDING SYSTEMS

Setups and Component Suggestions

Complete Stand Alone Broadcast System



An example of how vast and varied Triad-Orbit Systems can be used.



Components used in system at left: (1) T3c (2) O2x (3) IO-Desk (4) OA (5) IO-GC (6) iOrbit (7) IO-GCM (8) M2, (9) IO-A1A (10-above) System can easily be modified to your needs (ex IO-FLX or IO-A1A)

Desktop Podcast System



Components used in this system. (1) IO-GC (2) IO-EXT2S (3) IO-Vector (4) M2 x 2 (5) M3.

NOTE: This system could also be desk or wall mounted with IO-WSP or IO-W in place of IO-GC clamp.

Triad-Orbit Systems are completely modular and these systems are only suggestions. There are always several options that can fit your needs or placement space. Please see "Building Systems and Assemblies" on our website for many more creative ideas.

BUILDING SYSTEMS

Setups and Component Suggestions

Studio Vocal with Stereo Acoustic & iPad

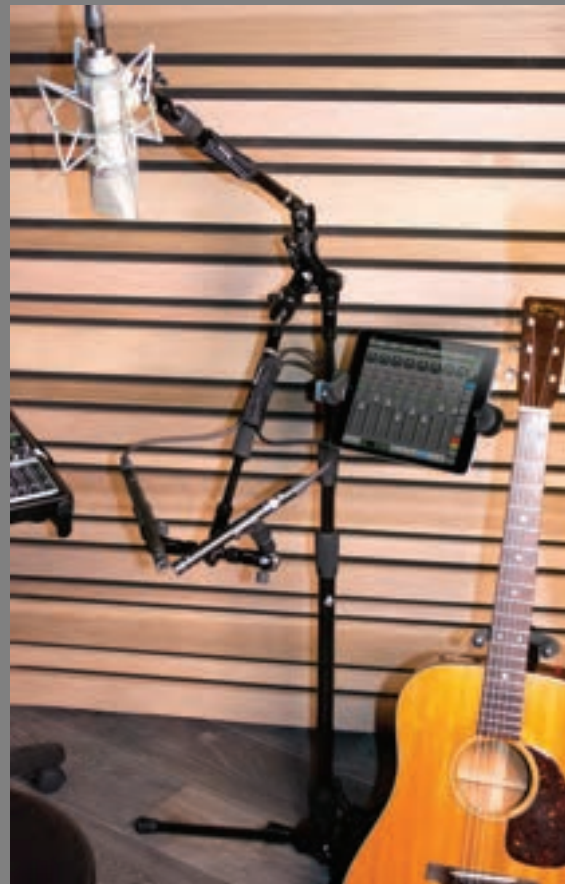

Components used in this system. (1) T3c, (2) O2x, (3) IO-Vector, (4) iOrbit, (5, 6 & 7) M2

Ceiling Mounted Boom System with iPad



Components used in this system. (1) IO-W, (2) IO-A2A, (3) IO-LCK, (4) IO-A1A, (5) iOrbit, (6) M2

Triad-Orbit Systems are completely modular and these systems are only suggestions. There are always several options that can fit your needs or placement space. Please see our website, "Building Systems and Assemblies" for many more.

Triad-Orbit's groundbreaking SM-1 speaker mounting system is designed for immersive sound installations and Dolby Atmos® systems. The base SM-1 system is comprised of the WM-1 wall or ceiling mount and SM-SW-1 swivel. This system features dual redundant locking mechanisms with 15° locking positions in tilt and 30° in pan axis. The speakers axes can be preset with SM-SW1 before mounting and then the complete assembly just slides into the SM-WM1 saving time in the alignment process. Please check our website or contact info@triad-orbit.com for the current matrix of compatible speakers and brackets, as the list is growing rapidly. SM-1 is certified as a system for a 100 lb load. **Note:** Some Small format speakers may mount directly onto the SM-1 swivel without the need of a speaker mounting plate.

SM-1 Precision Atmos Speaker Mounting System

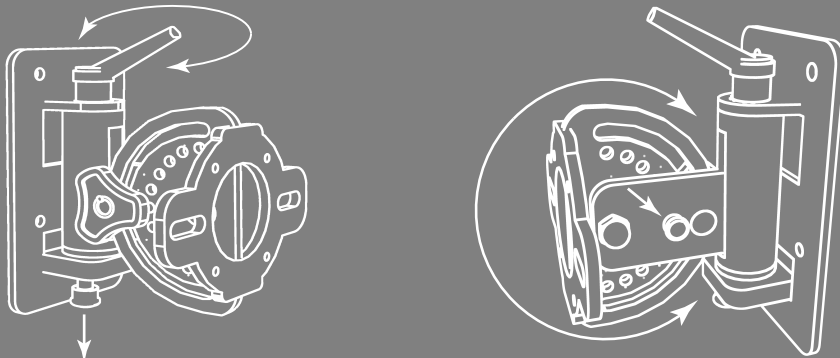

SM-SW-1 Swivel

The patented SM-SW1 is the main pan and tilt swivel for the SM-1 System. The SM-SW1 controls are redundant with both a locking spring pin and tension knobs.

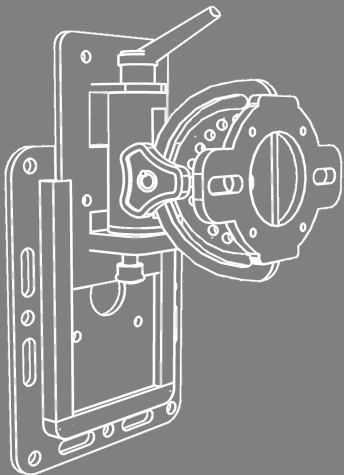

SW-WM1 Wall / Ceiling Mount

The patent pending design of the SM1 System utilizes a novel slide-in wall or ceiling mount. This allows the installer to set up the speaker and swivel assembly prior to hanging the speaker. The SM-WM1 also accepts the SM-PM1 pipe plate.

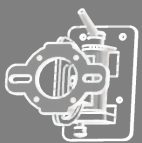

SM-SW1

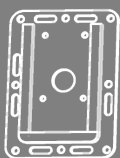

SM-WM1



Custom Speaker
Brackets or Plates

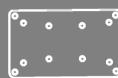

SM-PM1 Pipe Plates,
two are needed per system.

FUNDAMENTAL COMPONENTS OF THE SM-1 SYSTEM

- SM-SW1 swivel • SM-WM1 wall / ceiling mount • Custom speaker brackets or plates • SM-PM1 pipe mount plate



EASE OF SET UP

Once the SM-WM1 is mounted, the complete speaker assembly slides directly into the SM-WM1 and is locked in place with 4 provided hex screws.

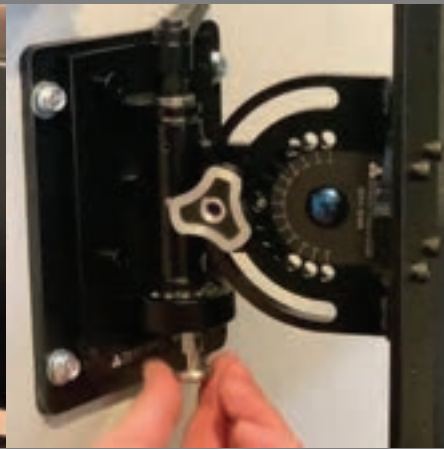

PAN ADJUSTMENTS

To move the swivel to the desired pan position, first loosen the tension knob and then pull the spring pin out. Pan as needed. Use the pin to find and lock in your desired position.



TILT ADJUSTMENTS

To move the swivel to the desired tilt position, loosen the tension knob and then pull the spring pin out. Use the pin to find and lock in your desired position.

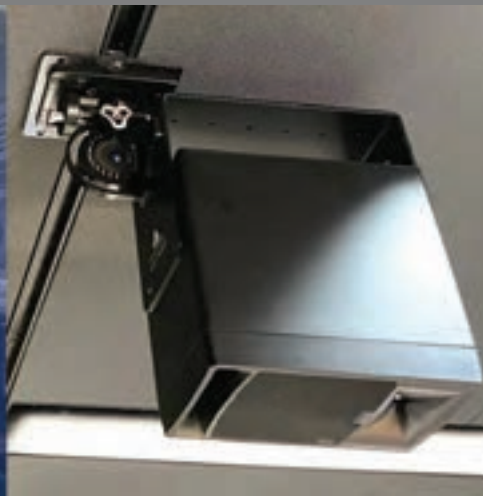

CUSTOM 'U' BRACKETS

The ever growing models of SM-1 custom 'U' bracket are designed to hold the speakers in a variety of positions. They have 5 different sets mounting points for the SM-SW1 swivel, allowing for optimum angles including 90° vertically or horizontally. This allows for ultimate flexibility, such as mounting a speaker either vertically or horizontally from the SW-1 swivel, or creative applications like mounting a speaker directly against a ceiling as pictured above.

CLOUD DROP-CEILING PIPE MOUNTING

Drop-Ceiling or wall extension mounting requires two SM-PM1 plates for each ceiling/wall mount. One SM-PM1 pipe plate slides into the SM-WM1 and has 3/4" threads for standard plumbing pipe. The second PM-1 plate screws against the back side of the SM-1 swivel.

The plates can be used for long drop hanging positions or extending length off the wall.

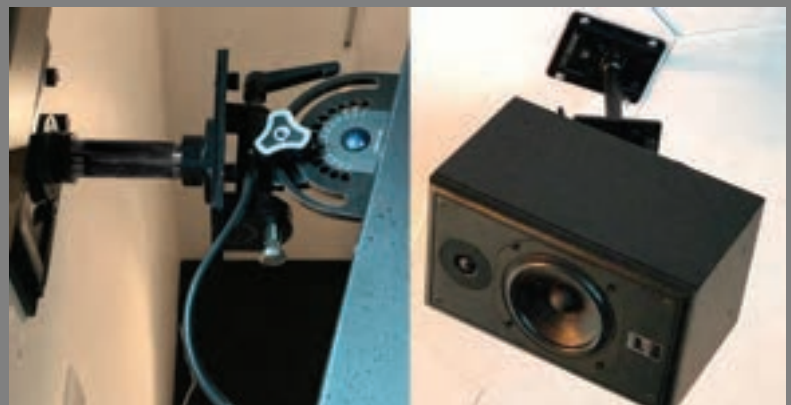

SM-UM1

Universal Speaker Mount

The Precision SM-UM1 is designed to accommodate a smaller, lighter range of speakers than the larger SM-1. As Immersive sound grows, smaller Atmos mix rooms are becoming more common, thus, the SPL levels are lower and are at a closer proximity and larger format studio monitors are less necessary. UM-1 does not use the pin locking system that SM-1 boasts, yet the powerful tilt function has built-in locking teeth. The pan knob has adequate strength to hold the pan adjustment in place.

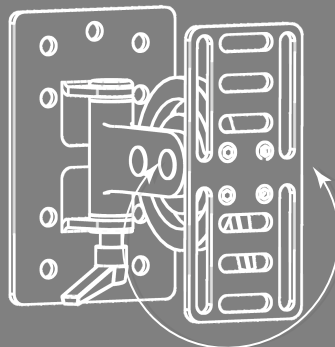
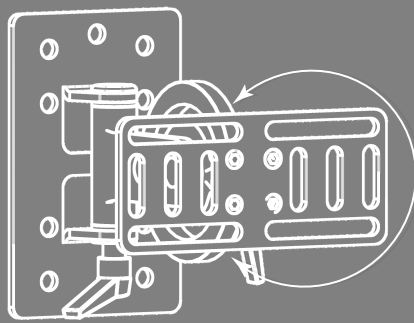
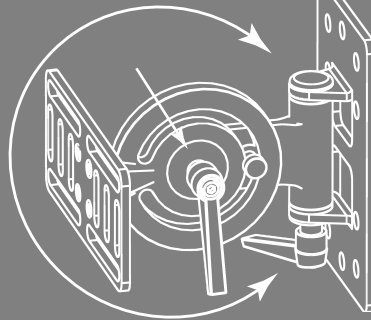
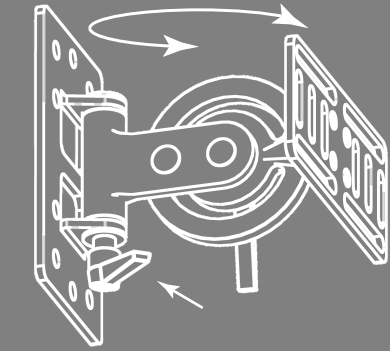

SM-UM1 is a stand-alone mount with a versatile mounting plate that can accommodate numerous speakers. However, it is designed so it can be used with the original SM-1 parts. SM-UM1 fits in the SM-WM1 wall mount. (Sold Separately)



This allows for one of the advantages of SM-1, such as ease of installation with a single installer. Simply mount the SM-UM1 to the speaker and like SM-1, slide the complete assembly into the wall mount.





REVOLUTIONARY

Triad-Orbit represents a quantum leap in the evolution of stands for audio, video, photography, lighting and industrial support. Every industry standard component, from stand bases to adaptors, was analyzed and reinvented. The result is Triad-Orbit: The first portable, pro-caliber modular stand systems for music, A/V, medical and industrial applications.

TRIAD-ORBIT.COM



CAT VOL4 Issue 2.0 /03012022



TRIAD-ORBIT
ADVANCED STAND SYSTEMS

ACCESS

8202 NE State Hwy 104, Ste 102 #23
Kingston, WA 98346 USA
(206) 780-1900

© 2022 ACCESS Products Group, LLC. All Rights Reserved